

# Integrated farming Manual

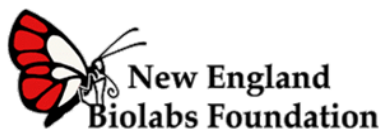



---

# Integrated farming Manual

## 2014

### Authors

Bartholomew Teul  
Kenny Cal  
Christopher Nesbitt  
Jaume Rusalleda

### Illustrations

Jill Burgess

### Editing & Layout

Erik Hammar

---



# Table of Contents

Foreword	1
Inga Alley Cropping on flat ground	2
Inga Alley Cropping on a slope	4
Agroforestry from Wamil	6
Agroforestry from Cabrucca	10
Pruning the cacao tree	12
Pig rearing	15
Composting	16
Applying compost	18
Biochar	19



## Foreword

Farming and farmers are at the very base of our culture and environment. They provide our communities with food and they shape our landscapes, interacting with nature on a daily basis in an interdependent way.

Through this manual, Ya'axché would like to highlight some of the most sustainable and income-generating farming techniques that can help farmers to improve their livelihoods, and also help to maintain landscape ecosystem services that are crucial for communities' present and future generations' well-being.

We would like to thank the Global Environmental Facility Small Grants Program for giving us the opportunity of continuing our work with communities and farmers, and the Maya Mountain Research Farm for their valuable input in the production of this manual.

Finally, we would like to acknowledge the hard work farmers do every day, and encourage them to keep on learning new and innovative ways to achieve economic and environmental sustainability.

# Inga Alley Cropping on flat ground

## What is Inga?

It is also known as bri-bri or bitz, and is a leguminous tree, which means that it can utilize gaseous nitrogen from the air by forming a symbiotic (two species living together) relationship with nitrogen-fixing bacteria. Its scientific name is *Inga edulis* and its common name in K'ekchi Maya is *chochokl* and in Spanish *guamo*.

## Why alley cropping?

It will increase corn yield and soil fertility, less weeds will grow in your corn field, you will need less land as you will be able to use the same plot for a longer time, it will provide you with fire wood, and it will keep the corn field humid and the corn healthier in dry weather.

## How is it done?

1. Ideally, you will set up three acres for Inga alley cropping that you will use in a rotational way (one acre per year). Plant Inga in the three acres as indicated in point 2. You can grow corn, beans, pepper, squash and other crops while the Inga trees are growing. You can also do this process in a single plot.
2. Plant Inga trees in rows. Trees should be planted 1,5ft apart (18 inches) along the row, and rows should be 10ft apart (as illustrated on the next page).
3. Plant the corn in rows in between the tree rows. You can plant the corn in rows separated by 2ft, leaving 1ft between corn plants, but you should adapt it to the local conditions or your traditional way of planting. Use the local variety of corn, at 2 grains per hole, as it will allow you to replant the same seeds the next year.
4. When the Inga is around 12-15ft high (which takes 2-3 years) and its canopy is shading the whole field, cut the tree trunk at around 5ft from the ground. This releases the nitrogen accumulated in the tree's roots into the soil, making it available for the corn. Nitrogen is a key nutrient and acts as a natural fertilizer. After the pruning you can plant the corn in the same way you did in point 3.
5. The tree will start re-growing from the cut. After harvesting the corn, you can move to the next acre of alley cropping, repeat the same procedure, and leave the used one to fallow so that Inga trees can regrow to 12-15ft again.
6. Leave the leaves on the soil, they will help improve soil quality and will prevent weed growth. Use the wood for domestic use or to make biochar (see page 19).
7. You can plant madre-de-cacao on the edges of your plots to act as wind-breakers.



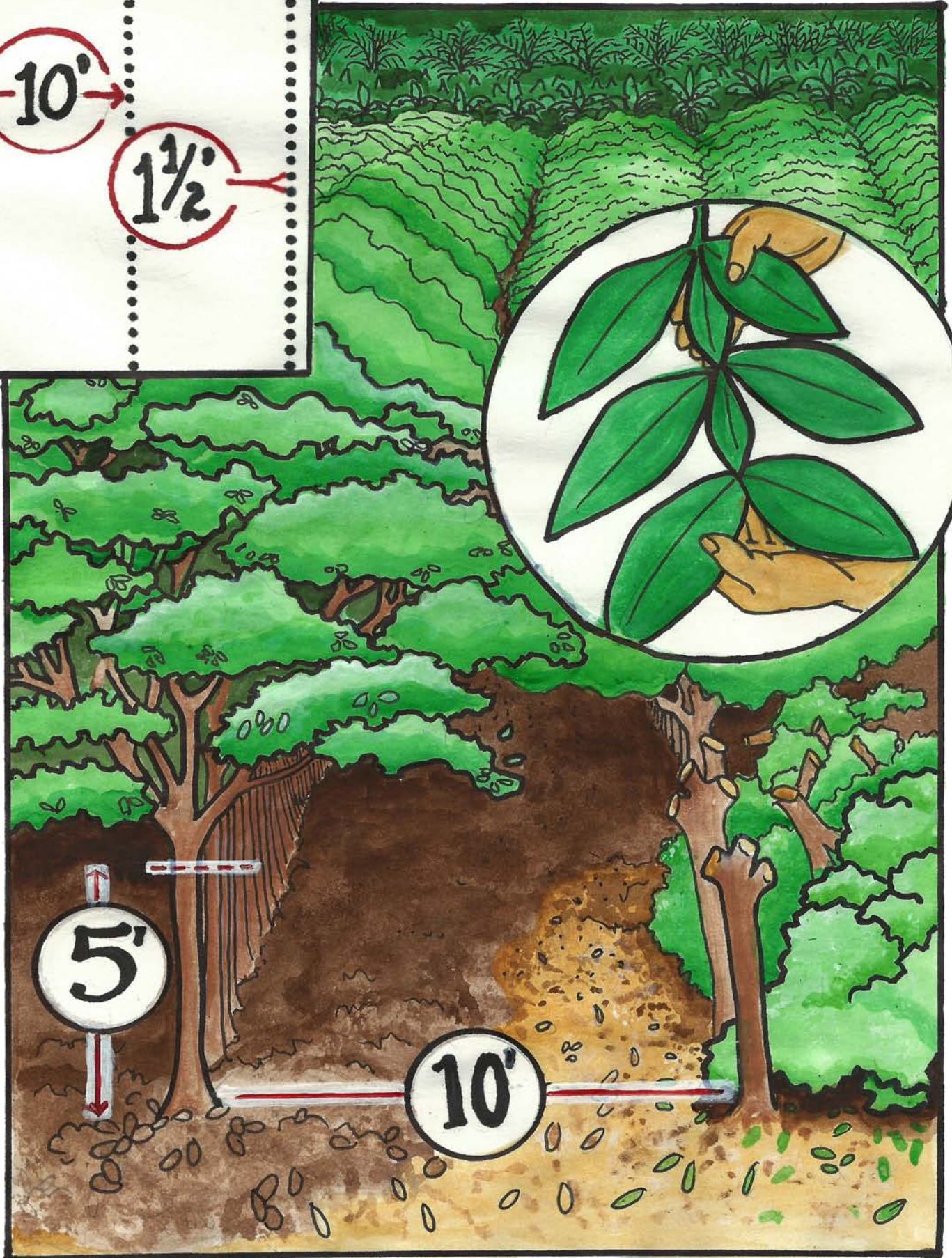
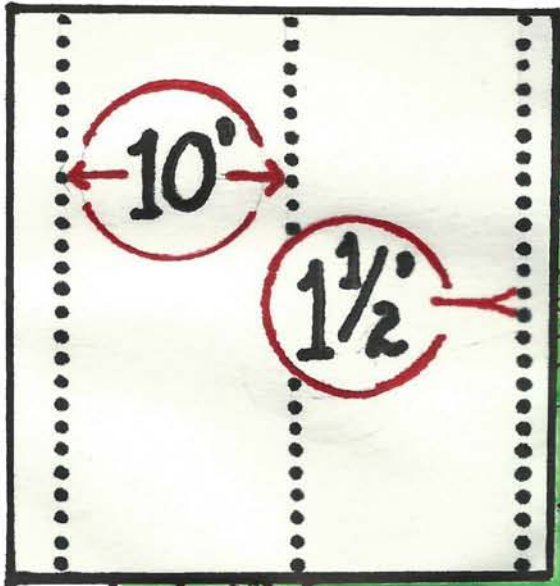

## Inga Alley Cropping on a slope

The benefits of Alley cropping on a slope are the same as explained in the previous section, and it includes soil loss prevention, as trees act to hold the top soil when it rains, allowing for a longer use of that same field. It is important that we conserve soil properly, especially on slopes, as it is very easy to lose and very hard to regenerate.

To make sure the Inga prevents soil from washing out during rains, you will need to plant the trees on contour lines, which are rows that have the same elevation (shown in the figure on the next page). To do so you will need an A-frame (shown below), which will help you find contour lines on your field.

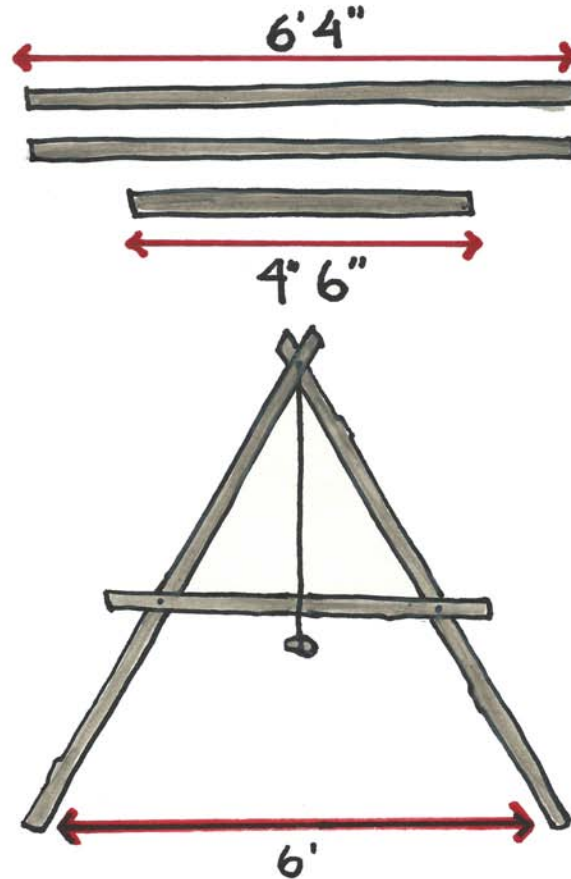



## Agroforestry from Wamil

In an area of Wamil that was previously used for milpa or cattle, you can clear any existing vegetation (leave cohune trees and any other valuable trees) and establish your cacao or coffee plantation.

Years 1 to 5 are very important for the future of your cacao or coffee farm. Take a look at the figure on the next page to understand how your farm should look in years 1, 5 and 10.

These are the trees that you can plant at different stages of your farm:

### Year 1

1. Pioneer species: they will create mulch, enrich the soil and provide economic benefit. They will also provide shade for cacao in its initial stages. These species are bananas, plantains, papaya, pineapple, pigeon pea, cassava, cocoa yam and lemon grass (especially appropriate on slopes).
2. Permanent shade trees. These are different types of shade trees that you can use to provide shade for your cacao. These include:
  - a. Fruit trees: like jackfruit, breadfruit, avocado, mango, golden plum, mamey, suriname cherry, golden plum, noni, anonna, peach palm, Malay apple, soursop, and many more. They will provide shade for the cacao and food and income from the fruit production.
  - b. Timber trees: samwood, mahogany, cedar, rosewood, santa maria, mayflower. These will provide shade for the cacao, and eventually when fully grown, income through sale of the timber.
  - c. Leguminous trees: Leucaena, Inga, bukut and mayflower. These will provide shade for the cacao and will also bring nutrients into the soil that will improve cacao tree production.

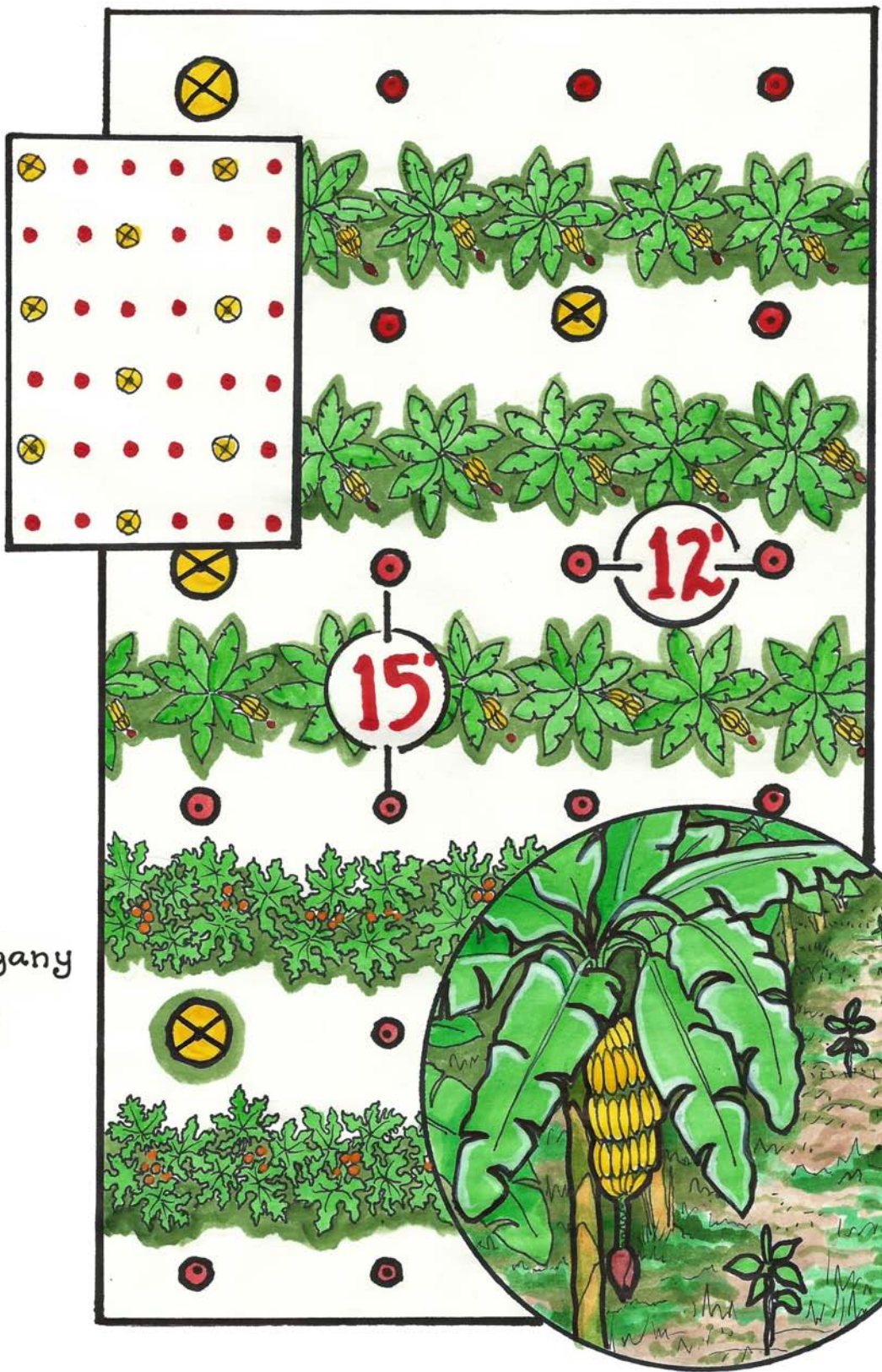

-  mahogany
-  cacao
-  banana plantain
-  papaya

## Year 2

Plant cash crop trees: grafted cacao and/or coffee. The shade generated by the plantains and bananas will be enough to plant the cacao/coffee trees under them in a 12ft by 15ft grid.

## Year 3-4

Some of the permanent shade trees will be high enough, so you can remove some of the temporary shade trees like the bananas and the Madre-cacao. At this point in time, shade on the cacao trees should be be of 60% approximately.

## Year 5

Your cacao trees should be bearing by this time, and your shade should be reduced to 40%.

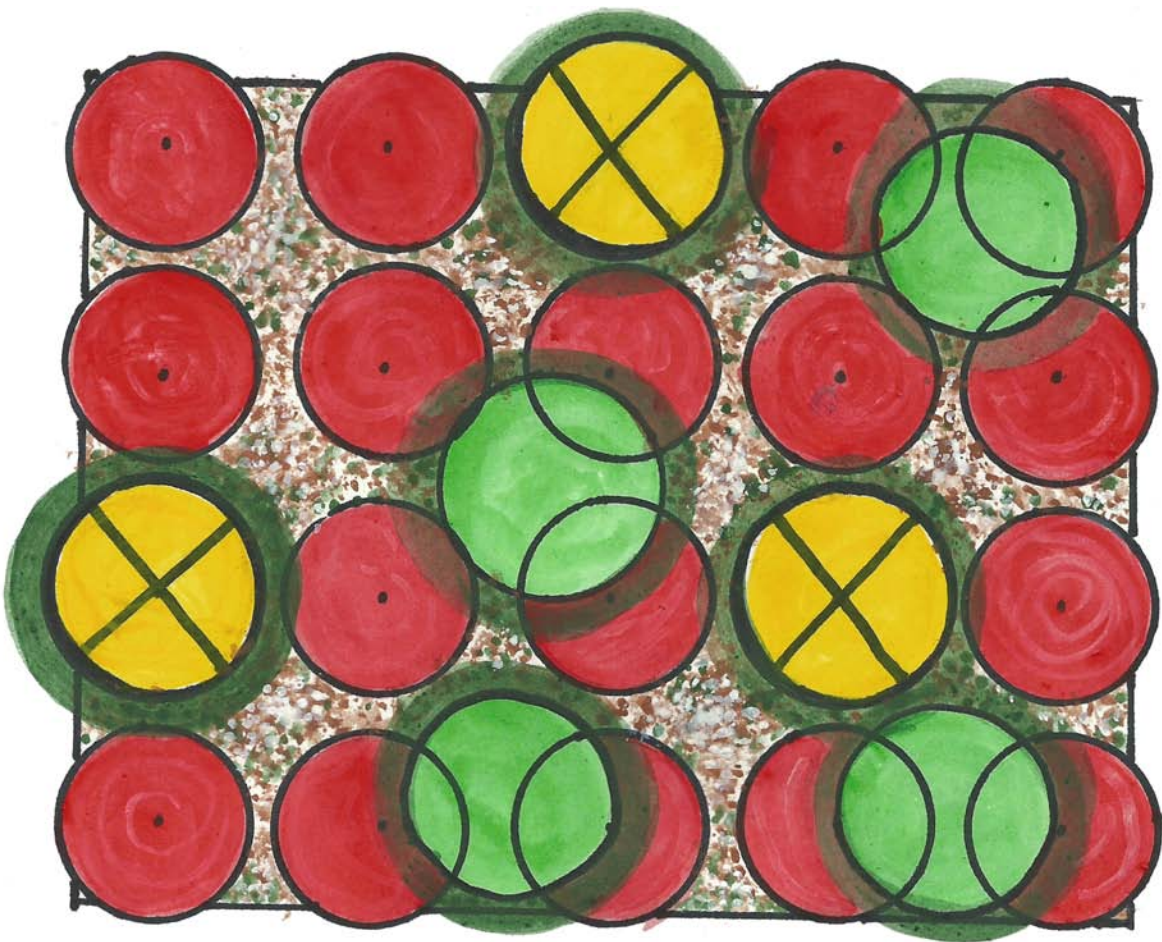

## Year 10

The cacao will keep on producing, and most of the fruit-trees will be producing already. You will need to bring down you shade level to 30% by taking out some of the shade trees, specially the leguminous trees like the Inga or Madre-de-cacao.

You can start adding more productive plants in your farm, like cardamom, vanilla, ginger, turmeric and black pepper.

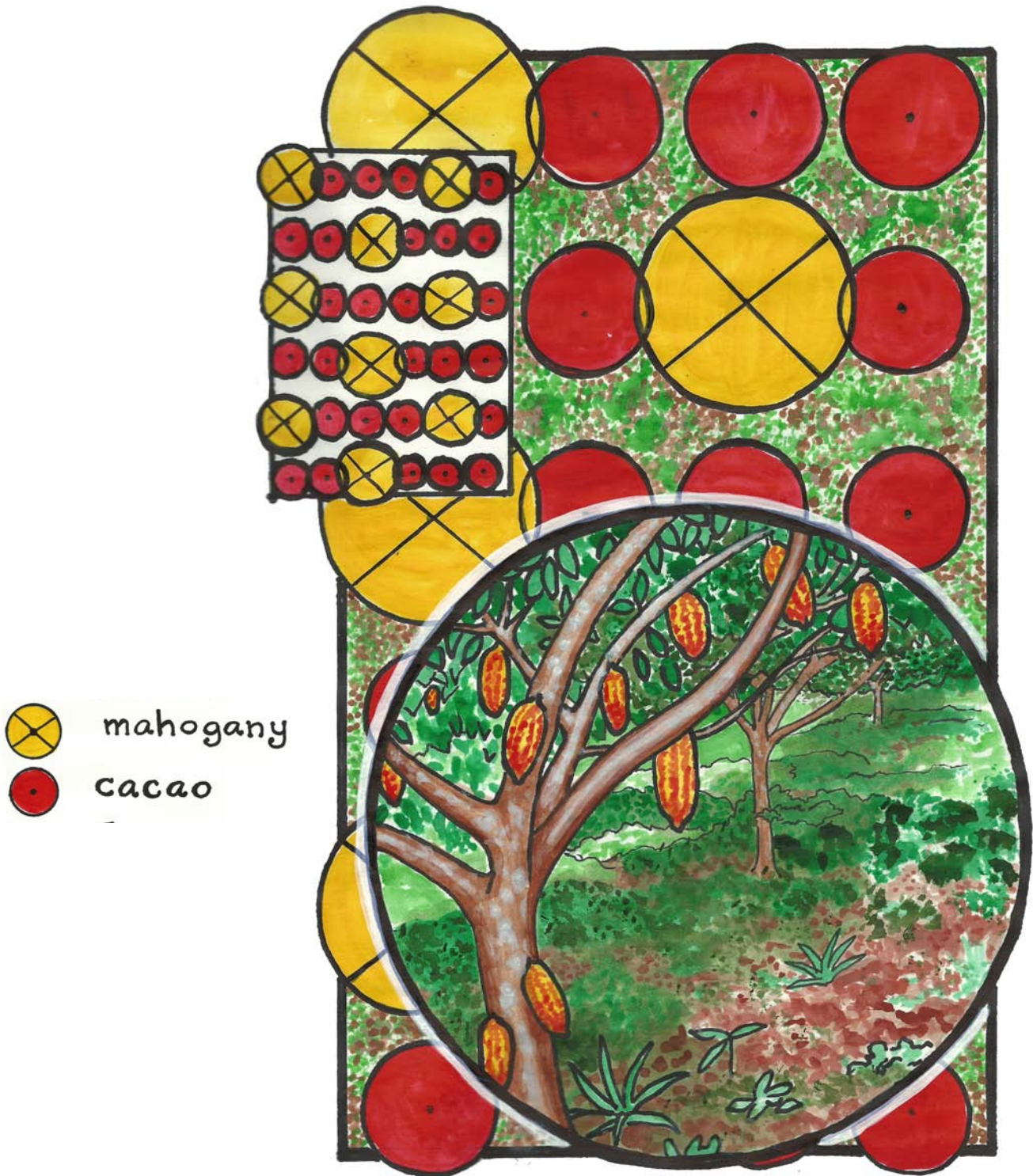

## Agroforestry from Cabrucca

In an already existing forest, you can create an agroforestry plot, and the first step has to be to thin the existing forest to a level where there is 60% of shade on the soil. Leave all economic valuable species like cohune, bay-leaf and any valuable timber trees.

### Year 1

Thin forest down to 60% shade and plant cacao or coffee trees in a 12ft x 15 ft grid as illustrated in the figure below.

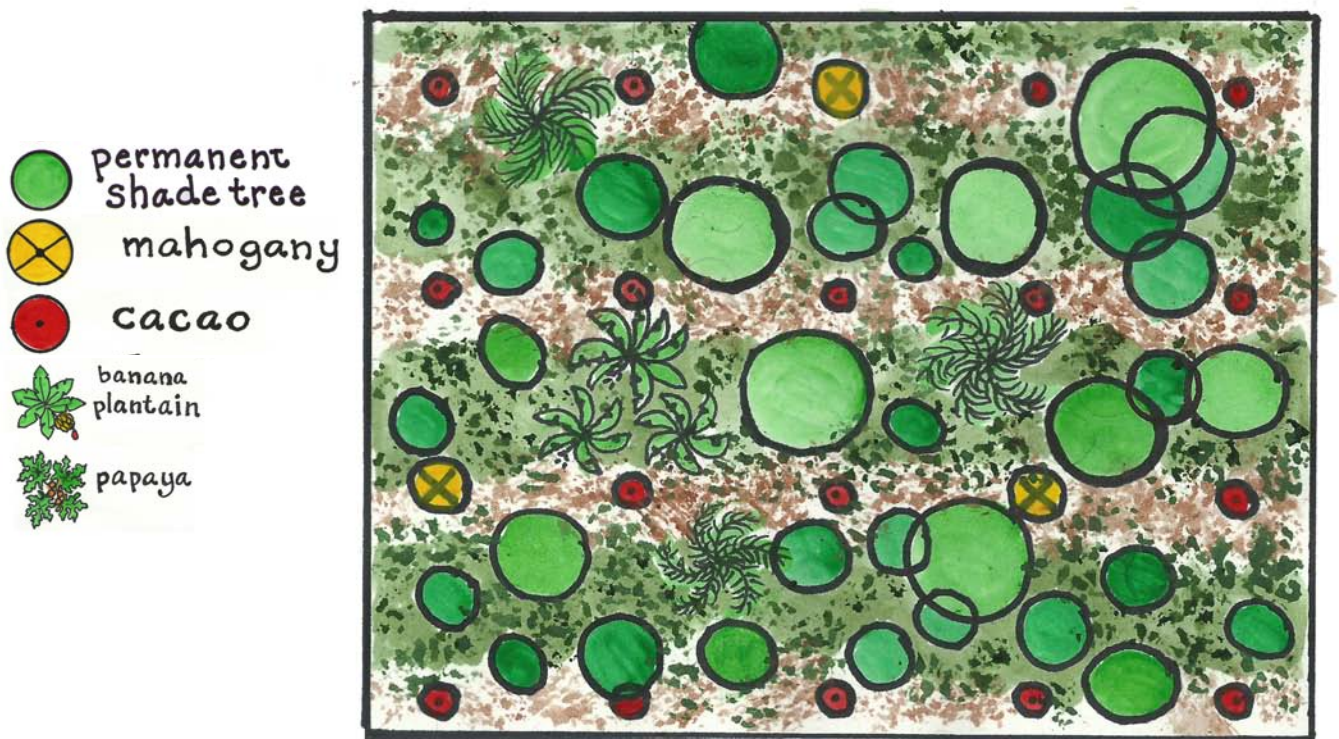



### Year 5

Thin forest down to 40% depending on local conditions (illustrated below).

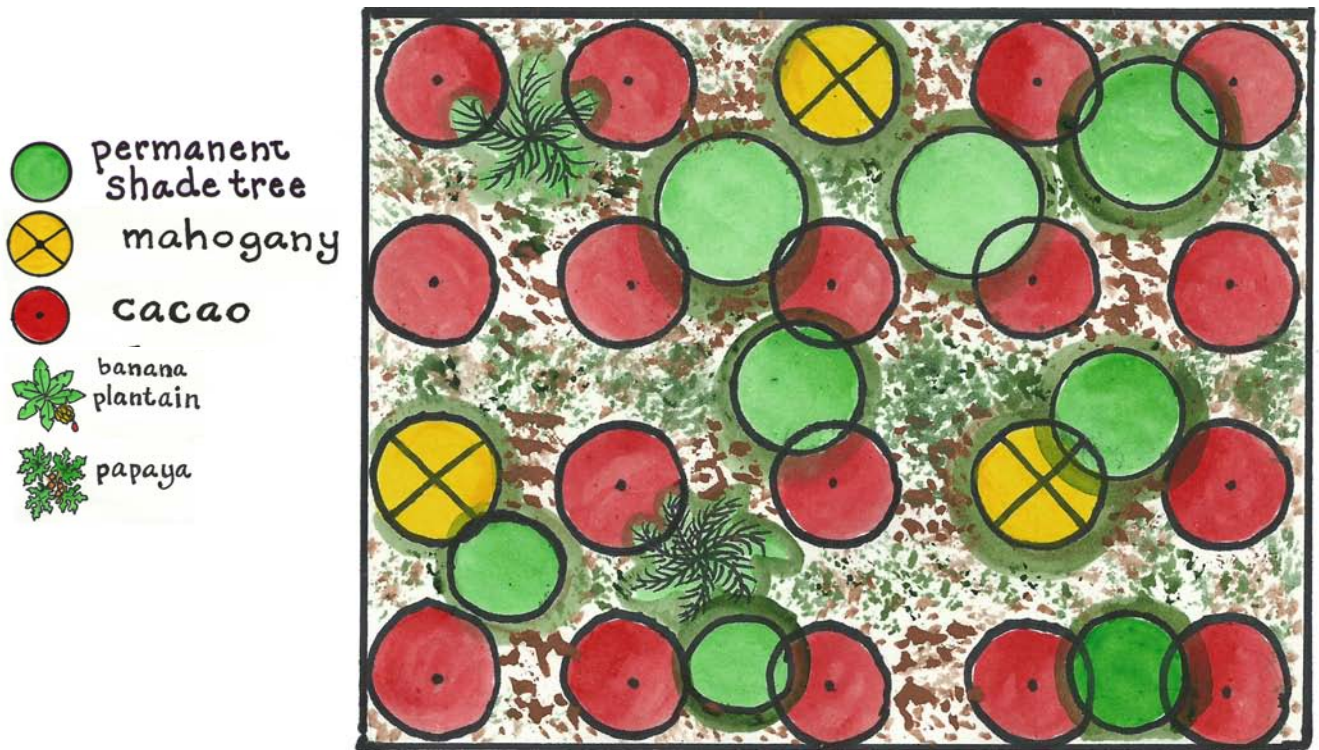

### Year 10

Thin forest down to 30% shade as shown in the illustration below. Prune your cacao trees on a yearly basis.

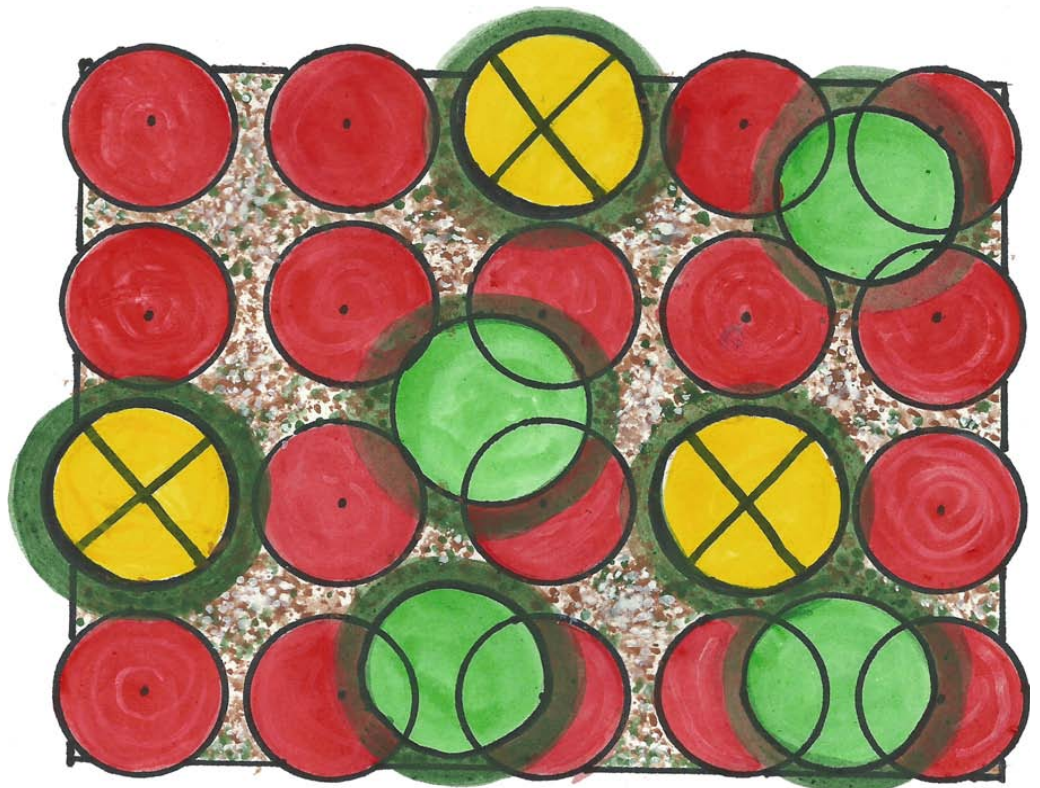

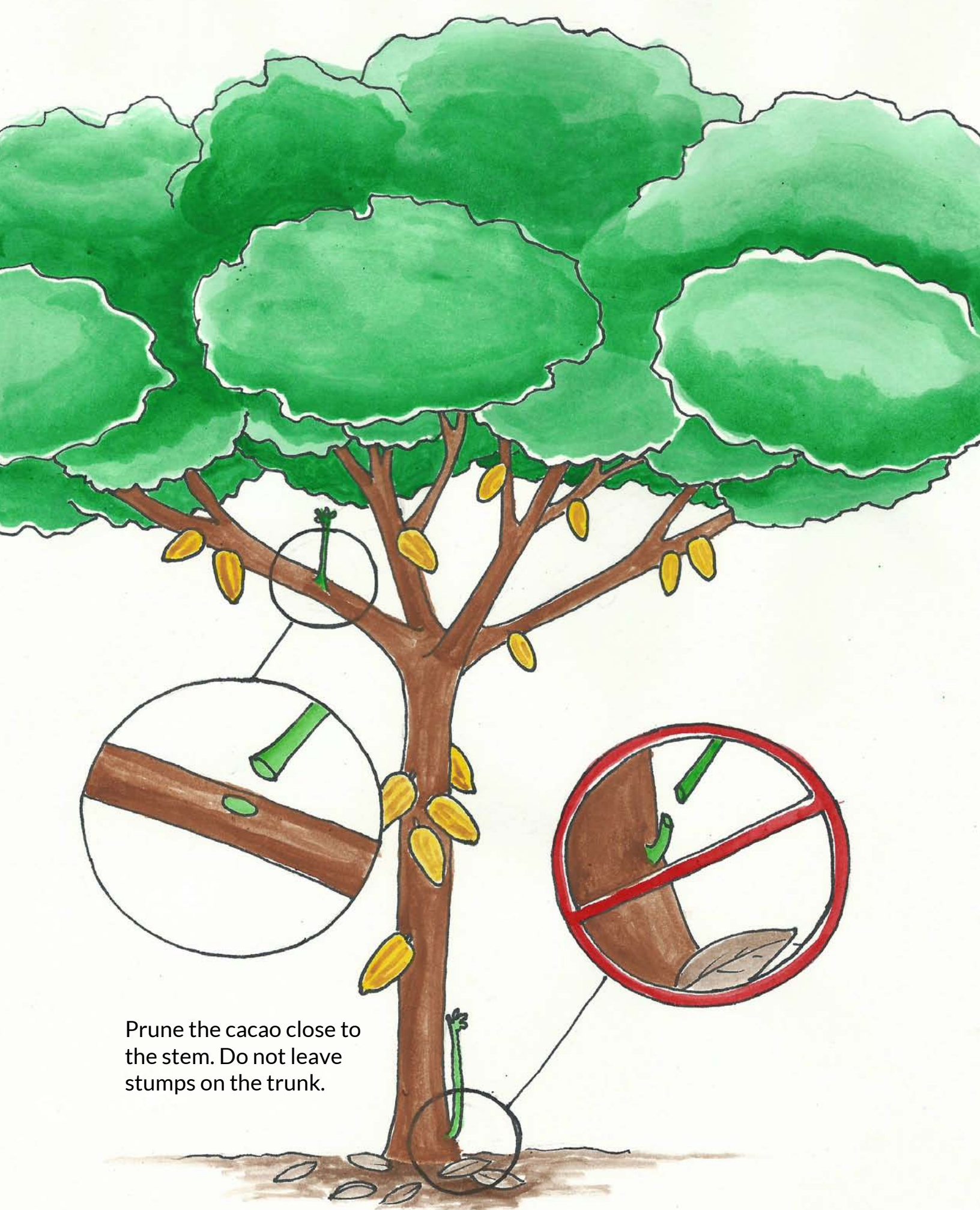

Prune the cacao close to the stem. Do not leave stumps on the trunk.

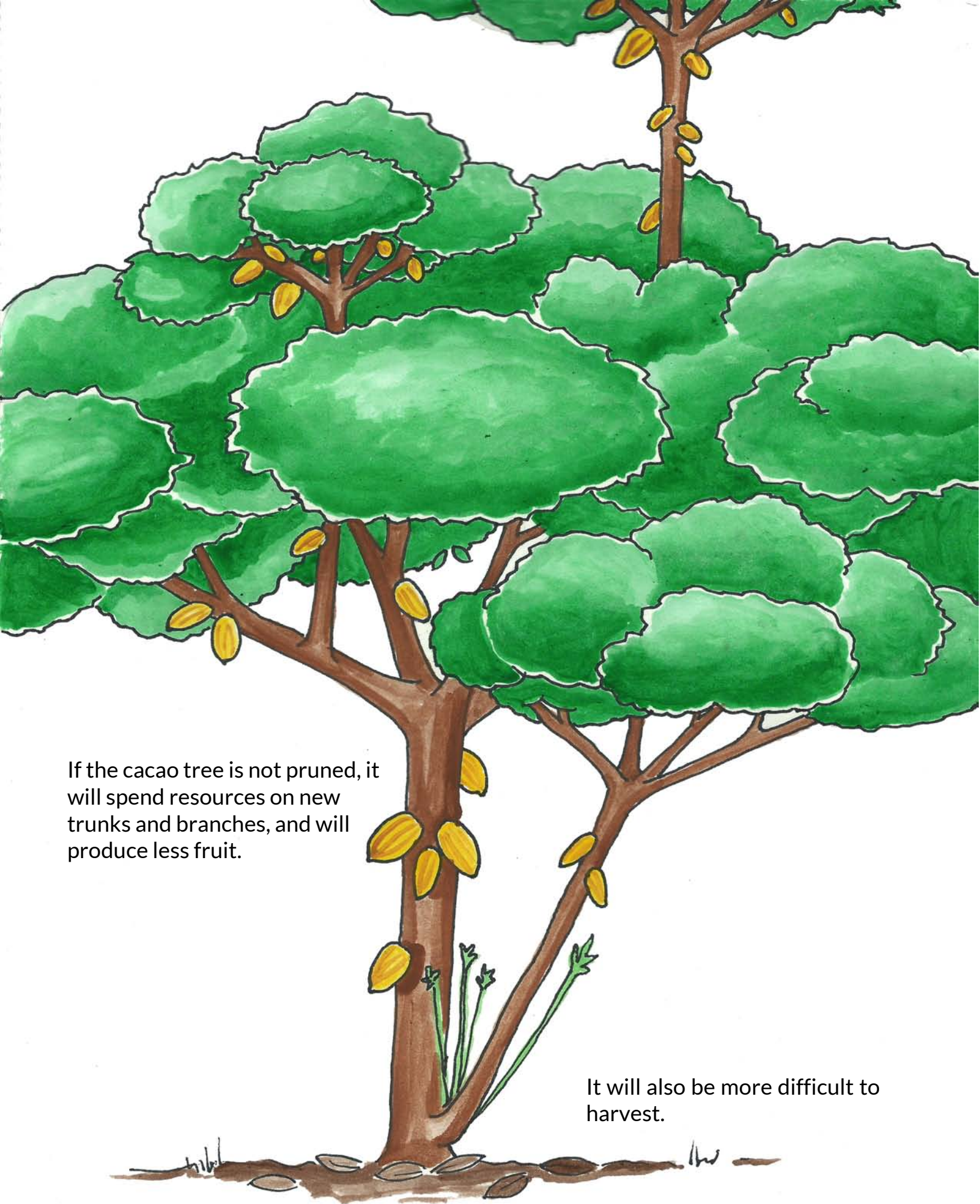

If the cacao tree is not pruned, it will spend resources on new trunks and branches, and will produce less fruit.

It will also be more difficult to harvest.

This drawing illustrates the change from a healthy pod (bottom right) to a pod fully infected with *Monilia* (top left).



Pruning the tree will increase cacao production and will help prevent diseases like *Monilia*.

## Pig rearing

Rearing pigs will provide you with meat for your consumption and for sale. It will also provide you with manure for composting. It is always preferable to rear the local pigs, which are better adapted to the conditions here than other species brought from outside.

To rear four pigs, you will need a central pen, with four different compartments. By having one boar and three sows, you can raise piglets for sale and butcher one of your pigs, now and again. The total size of the central pen should be 8ft by 10ft. This central pen will always have to be slightly tilted, so that the pig's manure can be hosed out of the pen in a regular basis. Manure can be collected and added to your composting bins, which will help enrich your soil and increase your productivity.



*Bird's-eye view of a pig pen.*

Around the central pen, you can build two fenced areas of 40ft by 50ft each, where pigs can get out of the pen. Pigs need to get out of their pen to walk around and root in the soil. This is an intrinsic behaviour that can be damaging if not controlled! However, we can use that behaviour to do work for us. Pigs enjoy doing this, so this is a way for us to make them have a better life.

In a rotational way, you can have the pigs in one of the two fenced areas for a few weeks/months and then move them to the other area. When one of the fenced areas is closed, you can plant corn, beans, sesame and cocoa yams that will grow very healthy due to the ploughing that the pigs do in the soil. The fence can be hog wire or chicken wire, 4ft above the ground and 6 inches in the ground.

## Composting

### Why composting?

To increase the yields of the crops, especially vegetables and fruit trees. You will have higher production and the plants will be healthier and the trees stronger. In the soil there are many kinds of small organisms (living things) called microorganisms. Two kinds that are important to the soil are bacteria and fungi, which break down organic material and make nutrients available to plants. Compost helps soil microorganisms in providing more nutrients to our plants so they can produce more.



It consists in accumulating different kinds of organic rejects, like branches, leaves, rests of vegetables, peels, food remains and animal excrements among many others. It decomposes (rots) and transforms into earth-like material that can be put in the soil for the plants to absorb through its roots. The most effective method is the three bin-method, which consists in having three different compartments to accumulate organic matter. This can also be done in three holes dug in the ground.

You first start accumulating organic matter in the first bin/hole. You must stir it after the first week. After the second week, you move it to the next bin/hole and start filling the first bin/hole again. You stir both bins every week. After two weeks in the second bin, you move the initial batch to the third bin/hole, and you move the content of the first bin to the second (and start filling the first again). After two more weeks in the third bin (six weeks in total), the compost will be ready to be used.



Vegetable crops prefer compost made by sticks, rests of vegetables, coffee grounds, pig manure, chicken manure, etc. (what we call green material). This makes compost that is dominated by bacteria which is great for increasing vegetable production.

Trees prefer compost made by leaves, rice holes and corn trash (what we call dry material). This makes compost that is dominated by fungi which helps trees grow stronger and healthier.

## How to apply compost?

### For trees

When planting trees (right figure): dig a whole with a post-hole digger, put two handfuls of compost and plant the tree, fill the rest of the hole with regular soil

On a grown tree (bottom figure): dig a trench where the drip line is in a circle, and bury the compost covering it with regular soil. If it is in a slope you want to put barriers at the bottom so it does not fall down.

### For vegetables

Dig in and plow the soil with the compost before planting the vegetables.

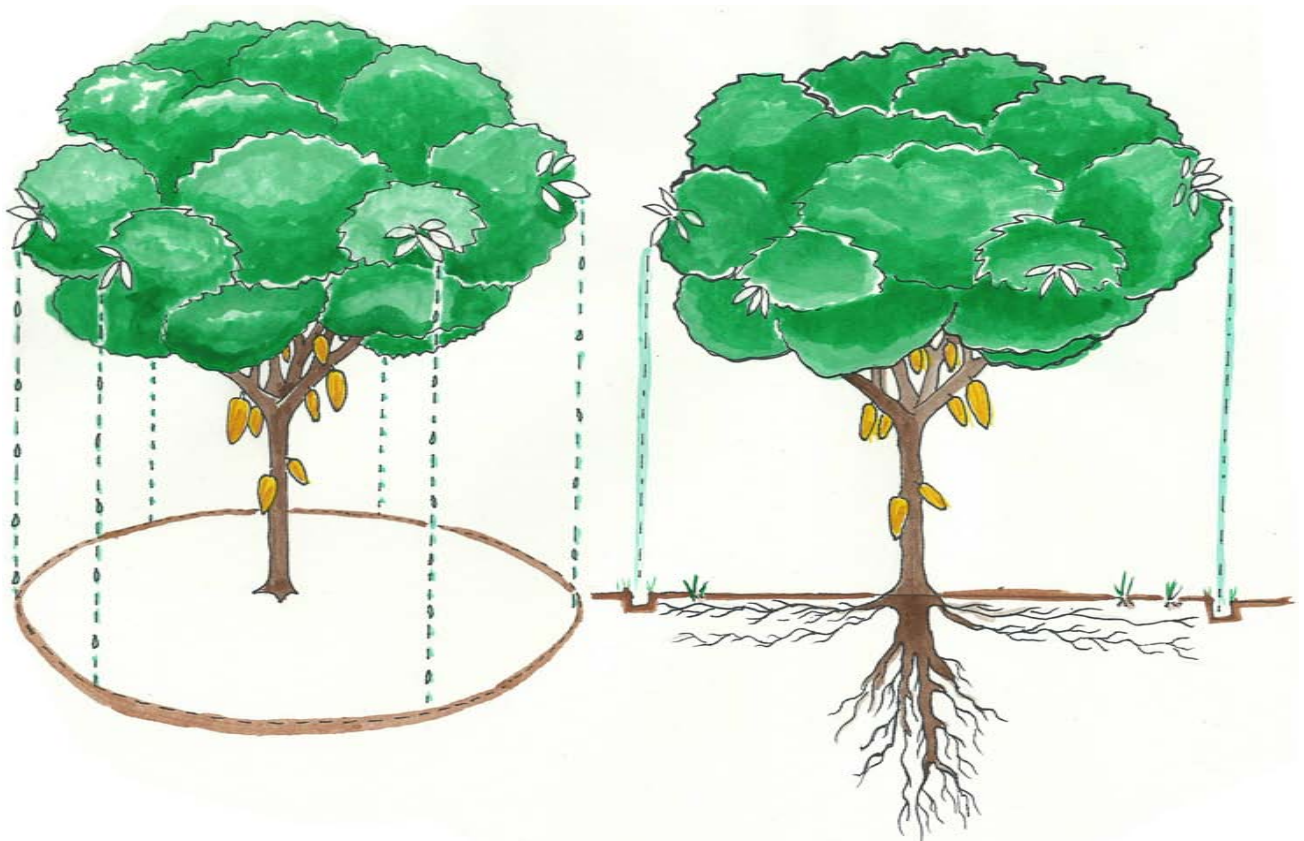
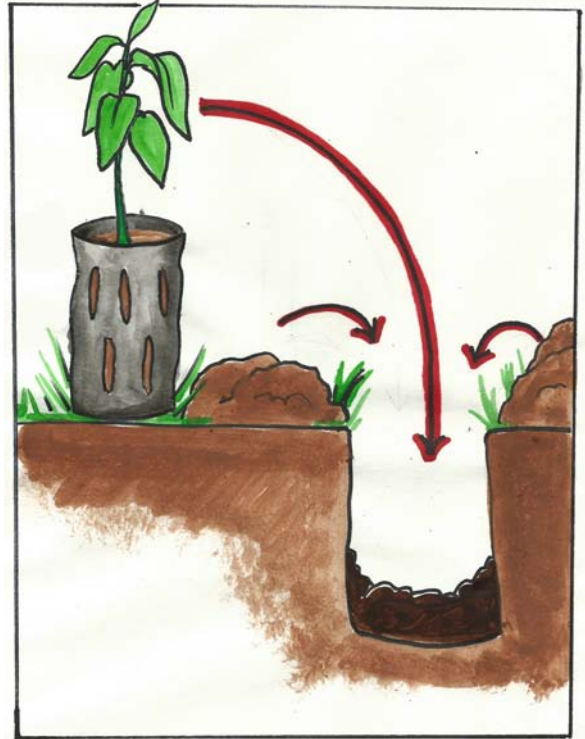



## Biochar

### What is Biochar?

It is a kind of charcoal. Wood is burned in such a way (without oxygen) that it creates extremely small holes in the biochar, which is a perfect home for fungi and bacteria that make the soil healthier and more productive.

### Why use Biochar?

To increase crop yield and improve soil conditions and soil health. Biochar is most effective when applied to the soil already mixed with organic matter and compost.

### How to make biochar?

We need a 55-gallon drum and a regular butane or propane gas tank. You will have to cut the bottom of the gas tank and find a metallic piece that fit on the tank. With the original valve open, put it in an inverted way and fill it with wood (sticks, rice holes, cohune seeds, bamboo, etc). Put the lid back on the gas tank. Set up the gas tank in the 55-gallon drum, and fill the space between them very densely with wood, preferably hard wood and thick sticks.

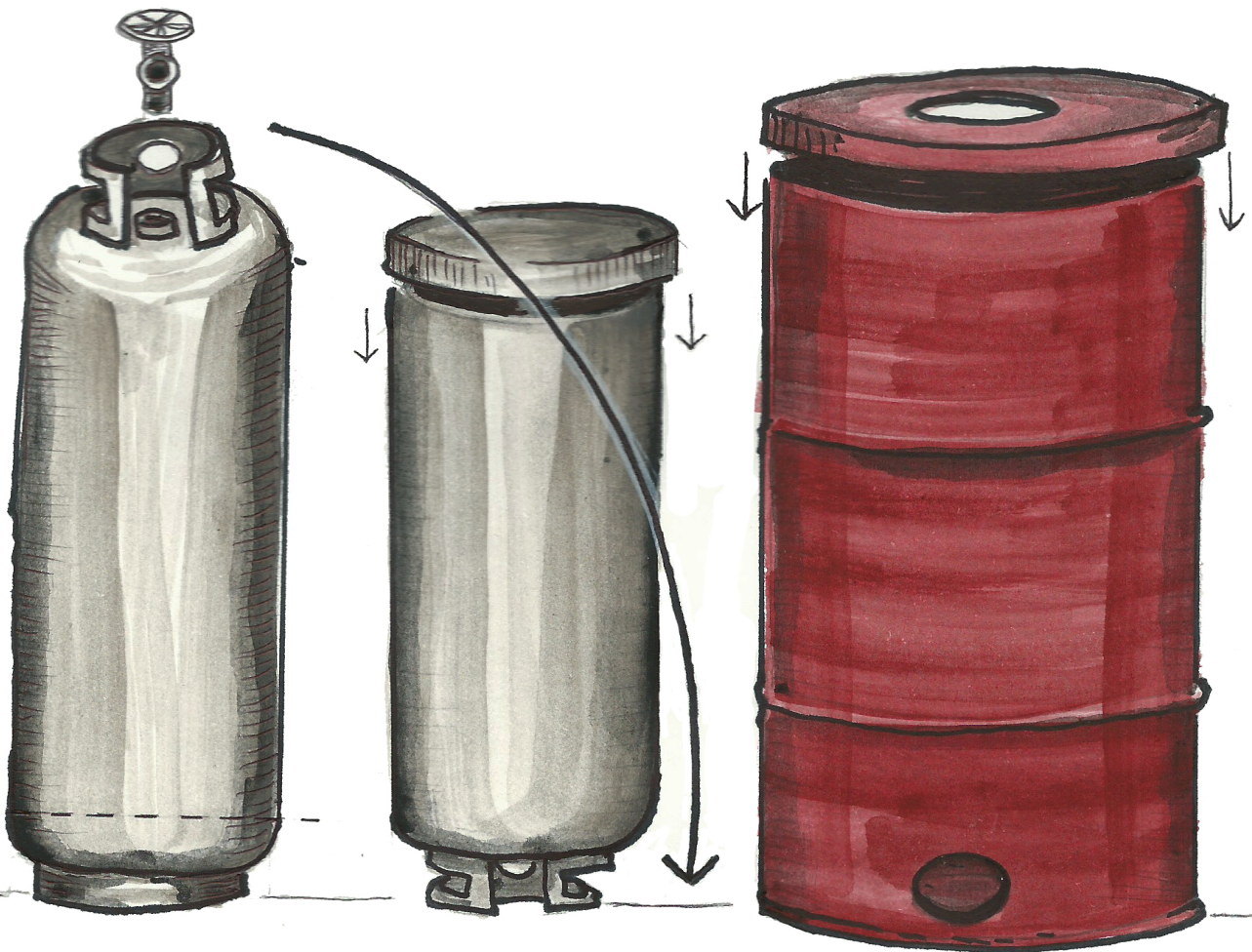

Make two holes at each side of the inferior part of the drum one will be used to light up the wood in the 55-gallon drum and the other one will allow for a better burning. Put on the lid on the drum, in which you will have to make a six-inch diameter hole to induce the stack effect and increase oxygen levels at the bottom. Light up the wood in the bigger drum through one of the inferior holes. You can use the heat generated in the process to cook food on the drum.

### How to apply biochar?

Biochar works best when mixed with compost. Crush the biochar and mix it in your composting bin or hole. If you have pigs, put the biochar inside their pen. The pigs will step on it, crush and dispose their excrements on it. When you clean your pigpen you can gather the processed biochar and pig manure, mix it with compost and apply it in the ground to your young trees, grown trees or vegetables.





**Ya'axché Conservation Trust**

22 Alejandro Vernon Street, P.O. 177  
Punta Gorda, Toledo District  
Belize

**Phone:** (+501) 722-0108

**Fax:** (+501) 722-0108

**E-mail:** [info@yaaxche.org](mailto:info@yaaxche.org)

**Web:** [yaaxche.org](http://yaaxche.org)